

Product Specification

Brigade Model Number: BE-500XC Series Camera
 Brigade Stock Code: BE-500HC (#2826B) - Horizontal Mount
 BE-500VC (#2828B) - Vertical Mount

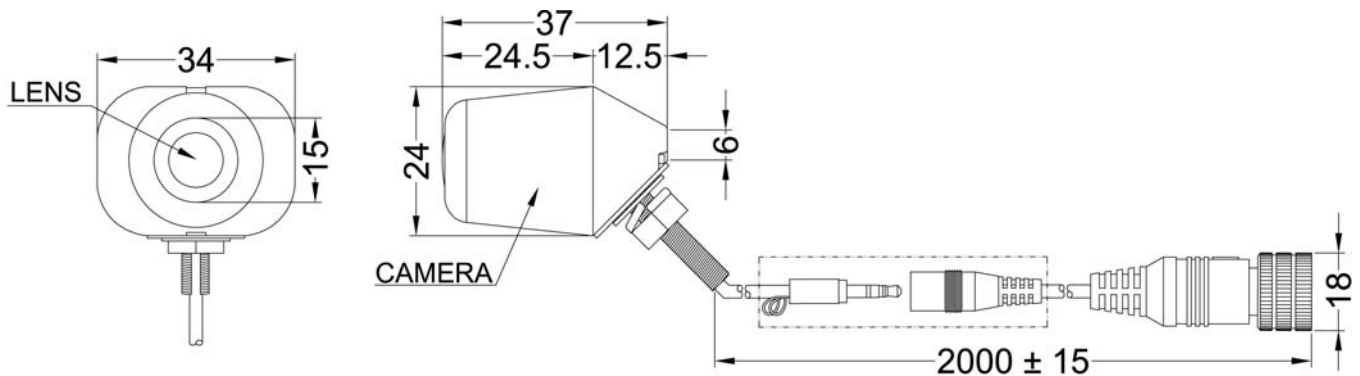

Dimensions: mm

Product Specification

Environmental Specifications:

- Vibration Rating: 10 G
- Camera IP Rating: IP68
- Connector IP Rating: Not Tested
- Operating Temperature: -25° to +80°C
- Storage Temperature: -40° to +90°C

Testing Standards:

- RoHS Compliant
- CE Marked
- EMC Approved to 2006/28/EC (e)
- EMC Approved to ECE R10.02 (E)
- Environmental Testing to HALT Standards

Technical Specifications:

- Operating Voltage: 12 ± 2 Vdc
- Current Consumption: 0.065A @ 12 Vdc
- Power Consumption: <0.85 Watts @ 12 Vdc
- Imaging Devices:
 - CCD - 1/4" Sharp
 - DSP - Sharp
- TV System: PAL
- Picture Elements: 512 (H) x 582 (V)
- Visual Resolution: 380 TV Lines
- Lens Focal Length: 1.62 ± 5%mm
- Image Transfer: Interline CCD Type
- Signal to Noise Ratio: <42dB
- Required Illumination: 0.1 Lux
- Microphone: N/A
- Shutter: N/A
- Internal Heater: N/A
- No. of IR LED's: N/A

Technical Specifications Continued...

- Viewing Angle:
 - 122° (H) x 94° (V) 154° ±5° (D)
- View: Mirror or Normal
- Weight: 80 Grams (Camera Only)
- Video Output: 1.0 Vp-p / 75Ω
- Length of Cable:
 - Camera Pigtail: 185 ± 5mm
 - Cable Adapter: 1820 ± 20 mm
 - Overall Length: 2000 ± 15mm
- Overall Dimensions:
 - 34mm (W) x 37mm (D) x 24mm (H)
- Finish: Black Powder Coated

Features:

- Back Light Compensation enabled.
- Automatic White Balance enabled.
- Automatic IRIS for a faster response.
- Horizontal & Vertical Flush Mounting Via Small Single Bolt (6mm).
- 154° Extra Wide Viewing Angle.
- BE Type Connector for easy integration with BE Monitors.
- Mirror or Normal View Set By Cutting Cable.
- Video Noise Reduction.
- Low Current Consumption.
- High Quality Sharp CCD & DSP.

Package Contents:

- 1x Camera
- 1x Cable Adapter
- 1x Installation Guide
- 1x Fixing Pack